

Tor V

Alarm transmitter
Installation manual

TABLE OF CONTENTS

| | | |
|-------|---|----|
| 1 | Introduction..... | 4 |
| 2 | Package contents | 5 |
| 3 | Conditions | 5 |
| 3.1 | Fire alarm installation (EN 54-21:2006)..... | 5 |
| 3.2 | Alarm installation (EN 50136/SSF 114)..... | 5 |
| 4 | Installation..... | 6 |
| 4.1 | Fire alarm installation (EN 54-21:2006)..... | 6 |
| 4.2 | Mounting..... | 6 |
| 4.3 | Antenna for wireless communication..... | 7 |
| 5 | Connections..... | 8 |
| 6 | Circuitry..... | 9 |
| 6.1 | Fire alarm installation (EN 54-21:2006)..... | 9 |
| 6.2 | Alarm installation (EN 50136/SSF 114)..... | 9 |
| 6.3 | Power supply | 9 |
| 6.4 | Alarm inputs..... | 10 |
| 6.5 | Relays (outputs)..... | 11 |
| 6.5.1 | Error indication..... | 11 |
| 6.5.2 | Indication of ongoing alarm..... | 11 |
| 6.6 | Ethernet connection (broadband)..... | 12 |
| 6.6.1 | Firewall configuration | 12 |
| 6.7 | Wireless connection..... | 12 |
| 6.8 | Reading the signal strength..... | 12 |
| 6.9 | Serial ports..... | 12 |
| 6.9.1 | Example of a cable for connecting the control panel..... | 13 |
| 6.9.2 | Example of a null modem cable for connecting a PC..... | 13 |
| 6.10 | Analogue dialler..... | 13 |
| 7 | Testing the fire alarm installation (EN 54-21:2006) | 14 |
| 8 | Maintenance | 14 |
| 9 | Troubleshooting | 15 |
| 9.1 | All diodes are blinking at the same time..... | 15 |
| 9.2 | The A diode is blinking and the C diode is turned off..... | 15 |
| 9.3 | Weak signal strength..... | 15 |
| 9.4 | No Internet connection..... | 15 |
| 10 | Data sheet Tor V..... | 16 |
| | Appendix – Status indicators for Tor V..... | 17 |
| | Appendix – Instructions for measuring the signal strength on a computer | 18 |
| | Appendix – Information for the building custodian | 19 |



0700

AddSecure AB, Telefonvägen 30, SE-126 26 HÄGERSTEN

18

2544-CPR-P21517-F01-18 (FIRE)
0700-19-210500-RED (RED)

SBF 110:8
SSF 114 utg. 2
EN 50131-1:2006:A2:2017
EN 50131-10:2014
EN 50136-1:2012+A1:2018
EN 50136:2:2013
EN 54-21:2011
EN 54-21:2006
EN 50130-5:2011
EN 50130-4:2011+A1:2014

Alarm transmission and fault warning routing equipment for intruder and fire alarm systems installed in buildings.

Notified body: Applicata Test & Certification

EN 55032:2015
EN 62368-1:2014
EN 62311:2008
EN 301 489-1 V1.9.2
EN 301489-52 V1.1.0 (on approval)
EN 301 908-14 V11.1.2
EN 301 511 V12.5.1

Notified body: Phoenix Testlab

Tor V: 80 321 335
Technical data: See this document

1 INTRODUCTION

The Tor V alarm transmitter is connected to an appropriate alarm transmission service, which is determined by the requirements for the alarm system. The transmitter itself does not need to be programmed; all the programming is done in the service. Communication depends on the version of Tor V and the connection: wired by Ethernet and/or wireless over the 2G, 3G, and 4G mobile data network. Communication is encrypted by AES to prevent unauthorized interception of or tampering with sent messages.

Tor V is constructed to securely transmit fire alarm, intruder alarm, and technical alarm signals. In addition, Tor V is equipped with a local Ethernet user interface to transmit IP-based communication from equipment connected locally.

Several service options can be selected for Tor V, all of which contain up to 8 alarm inputs. Depending on the service, the connection can be monitored with error reporting within 20 seconds.

For the alarm transmitter to meet the requirements of SBF 110:8, the delivered service profile must also comply with the requirements set forth in EN 54:21, including error reporting within 90/180 seconds (wired connection/wireless connection), and the installation is to follow specific instructions for the installation of fire alarms. See section 3.1 for all conditions.

For the alarm transmitter to meet the requirements of SSF 114/EN 50136, the delivered service profile must also comply with the requirements set forth in EN 50136, including error reporting, and the installation is to follow specific instructions for the installation of alarms. See section 3.2 for all conditions.

Keep an eye out for these two symbols that are used in this manual.



These two symbols indicate a warning or information to be aware of in terms of special requirements, exceptions, or other items worthy of noting.

AddSecure AB
Telefonplan 30
S-126 26 Hägersten
Phone: +46 (0) 8 685 15 00
Web: <http://www.addsecure.com>

Technical Support
Phone: +46 (0) 8 685 15 50
E-mail: support@addsecure.com

Every conceivable measure has been taken to ensure the accuracy and completeness of this documentation. However, as errors can never be fully excluded, we always appreciate any information or suggestions for improving the documentation.

We wish to point out that the software and hardware terms as well as the trademarks of companies used and/or mentioned in the present manual are generally protected by trademark or patent. Some components of the software used in the alarm transmitter are licensed under GPLv2.

© 2018 by AddSecure AB
All rights reserved.

2 PACKAGE CONTENTS

Tor V alarm transmitter in a plastic encasement

- This user manual
- Commissioning instructions (47IN0039)
- Installation manual – Removal detector (47IN0051)
- Tor V (alarm transmitter)
- Removal detector
- Internal antenna
- Ethernet cable (shielded)
- SIM card
- Sticker to mount on the fire alarm (EN 54-21:2006)
- Labels to mark the connections and indicators on the alarm transmitter
- Screws and plugs for installation
- External antenna for 4G (GPRS/EDGE/4G)
- Option: AC/DC adapter 230V/24V

3 CONDITIONS

3.1 Fire alarm installation (EN 54-21:2006)

- The service profile of the alarm transmitter is to meet the requirements set forth in SBF 110:8 (EN 54-21:2006).
- The alarm transmitter is to be mounted and connected so that all requirements in SBF 110:8 (EN 54-21:2006) are met.
- The pin inputs and relays are connected to meet the requirements set forth in SBF 110:8 (EN 54-21:2006). Use inputs normally closed or with a resistor to detect failure.
- The alarm transmitter is to be mounted and voltage supplied from the control panel.
- Access to voltage supply from the control panel, with 2A fuses.
- Externally mounted antenna with satisfactory signal strength for mobile data communication.
- Marking the outside of the alarm transmitter's encasement with the included sticker.
- Follow the instructions in the following sections: 4.1, 6.1, 6.5 and 7

3.2 Alarm installation (EN 50136/SSF 114)

For security class 2, the following apply:

- Tor V in a plastic encasement without a battery backup but with a mounted removal detector.
- The service profile of the alarm transmitter is to meet the requirements set forth in SSF 114:2/EN 50136.
- The pin inputs and relays are connected to meet the requirements set forth in SSF 114:2/EN 50136. Use inputs normally closed or with a resistor to detect failure.
- The alarm transmitter is to be mounted and connected so that all requirements set forth in SSF 114:2/EN 50136 are met.
- Access to voltage supply of +12V to +30V with battery backup, with 2A fuses for 12V.
- Follow the instructions in the following section: 6.2

4 INSTALLATION

The alarm transmitter is always to be mounted on a fixed, flat surface before it is connected. There must be sufficient space to connect the antenna and cables to the alarm transmitter.

4.1 Fire alarm installation (EN 54-21:2006)

For a fire alarm installation, it's easiest to mount the alarm transmitter inside the control panel. This is so that the installation complies with EN 54-21:2006. Attach the included sticker with the marking EN 54-21 to the outside of the encasement so that it can be read after the installation is complete.

4.2 Mounting

Mount the base using three screws using either holes A or B.

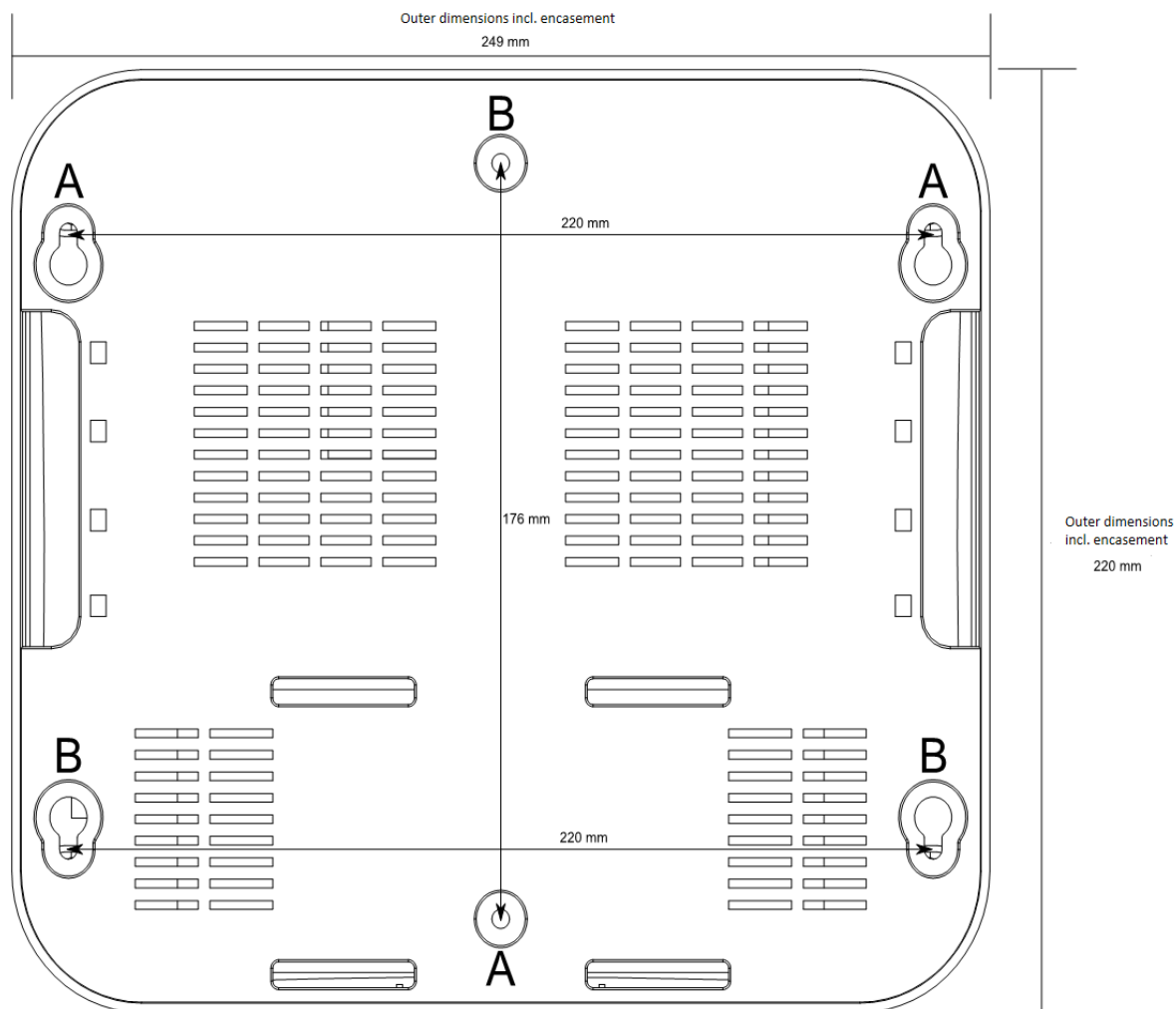

Figure 1 - Plastic encasement as seen from below

4.3 Antenna for wireless communication

Use the external antenna as needed, and place it so that the reception is satisfactory (do not place in a metal cabinet). Connect the antenna directly into the FME female socket. If the antenna is placed 5–10 meters from the alarm transmitter, use a coaxial cable of the type RG58.



Note that with wireless transfer over a mobile data network, there must be satisfactory radio coverage. See the signal strength using a computer (see the appendix) or LEDs during installation (see 6.8). Satisfactory signal strength is between 14 and 32.



Relieve the various cables (the ones connected to the alarm transmitter) of stresses by securing them outside the encasement, approximately 10 centimeters away. The plastic encasement also has prepared holes for cable ties on the bottom of the case.



When the plain text function or analogue dialler from the control panel is used, the external antenna must always be used so that the telecommunication signals from the control panel are not disturbed.

5 CONNECTIONS

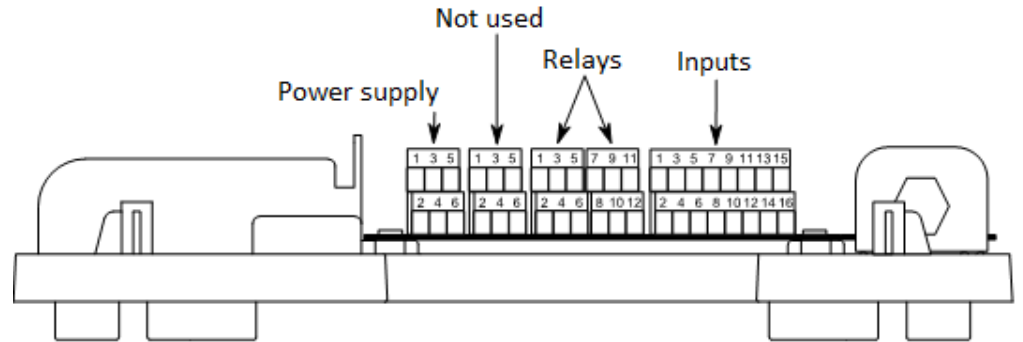

Figure 1 – Plastic encasement side 1

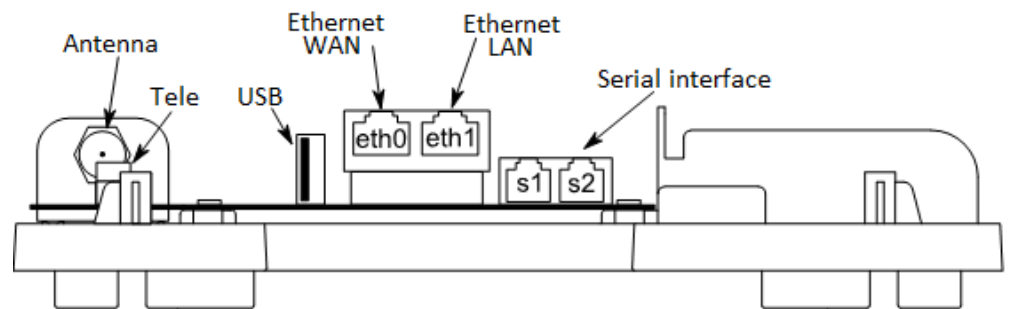

Figure 2 – Plastic encasement side 2

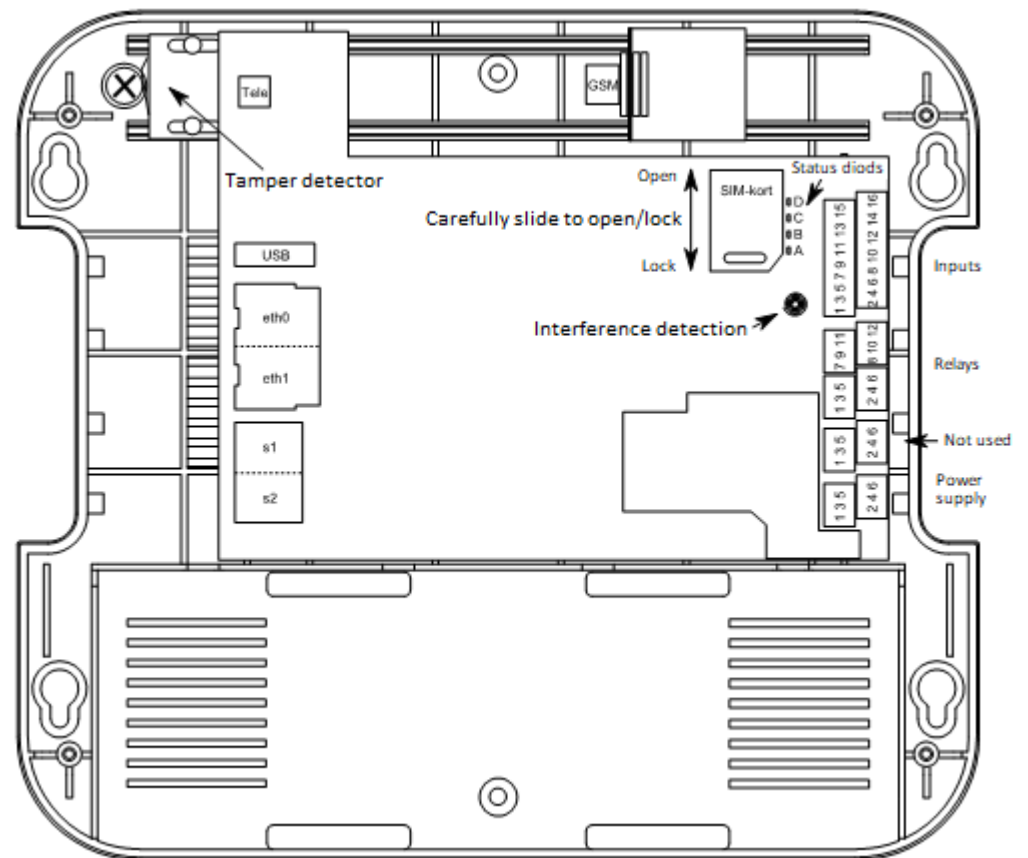

Figure 3 – Plastic encasement from above

6 CIRCUITRY



Relieve the various cables (the ones connected to the alarm transmitter) of stresses by securing them outside the encasement, approximately 10 centimeters away. The plastic encasement also has prepared holes for cable ties on the bottom of the case.

6.1 Fire alarm installation (EN 54-21:2006)

- Connect relay 3 (for error indication) to the control panel. See 6.5.1 for connection instructions as well as a data sheet (see 10) for details regarding the signaling and levels of the output.
- Connect relay 4 (for alarm acknowledgments from the alarm receiver) to the control panel. See 6.5.2 for connection instructions as well as a data sheet (see 10) for details regarding the signaling and levels of the output.
- Connect the control panel's output for error indication to optional alarm input. Balance the output from the control panel with 4.7kΩ.

6.2 Alarm installation (EN 50136/SSF 114)

To meet security grade 3, the removal detector must be mounted. See the included instructions on how to mount it (Installation manual – Removal detector 47IN0051).

- Connect relay 3 (for error indication) to the control panel. See 6.5.1 for connection instructions as well as a data sheet (see 10) for details regarding the signaling and levels of the output.
- Connect relay 4 (for alarm acknowledgments from the alarm receiver) to the control panel. See 6.5.2 for connection instructions as well as a data sheet (see 10) for details regarding the signaling and levels of the output.

6.3 Power supply

| PIN | |
|-----|--|
| 1 | Primary voltage supply +12V to +30V DC, with 2A fuses at 12V DC |
| 2 | Ground |
| 3-4 | Not used |
| 5 | Secondary voltage supply See pin 1 |
| 6 | Ground |

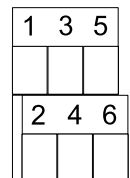

Figure 5 - Power supply terminal block

6.4 Alarm inputs

The alarm transmitter can either be digital and trigger an alarm when open or closed or analog, balanced at 4.7kΩ. A number of typical installations are described below.

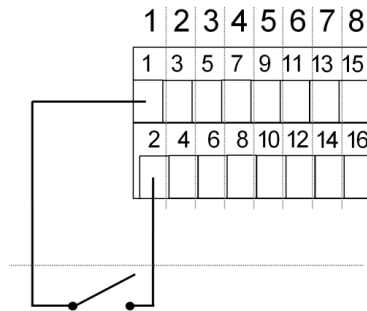

Figure 4 – Normally open/closed relays

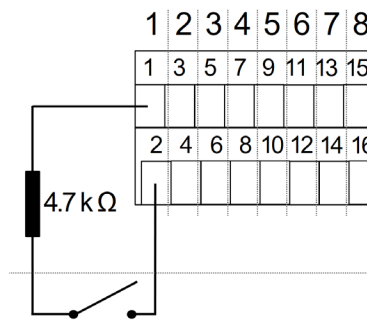
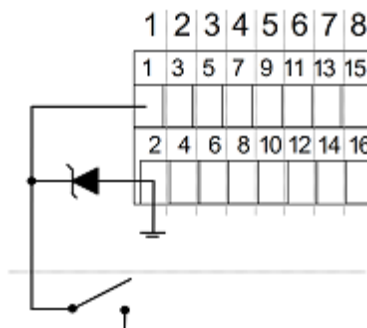
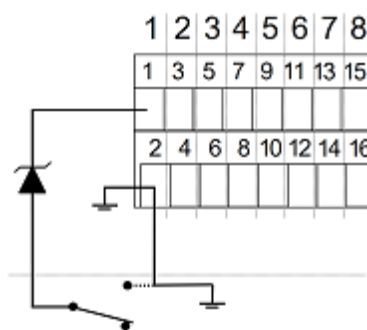

Figure 5 – Balanced analogue



***** +5V to 12V (Max 10mA)
Figure 6 – Voltage of +5V to +12V with limiting



***** -12V to -5V
Figure 7 – Voltage of -12V to -5V

1. Normally open/closed relays

When connecting the digital signals to trigger an alarm when opening or closing, the inputs are connected as such.

This connection can keep the control panel galvanically isolated from the alarm transmitter.

2. Balanced analogue

If the signals that are sent to the alarm transmitter are analogue, balanced at 4.7kΩ, the resistor is to be mounted as such.

This connection can keep the control panel galvanically isolated from the alarm transmitter.

3. Voltage of +5V to 12V with limiting

In some cases voltage must be limited on the alarm port in the alarm transmitter in option 3. If that is the case, insert a 5.1V Zener diode as illustrated in the sketch.

This connection can keep the control panel galvanically isolated from the alarm transmitter.

4. Voltage of -12V to -5V

The connection works no matter whether the output from the control panel is low ohmig (<500Ω) or high ohmig (>500Ω) when there is an absence of voltage.

This connection galvanically couples the control panel and the alarm transmitter.

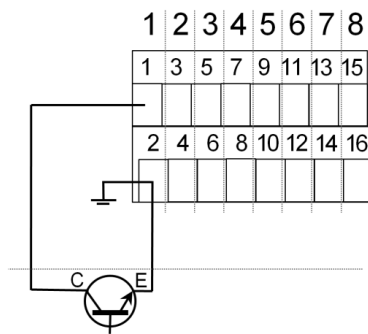

Figure 8 – Open-collector transistor

5. Open-collector transistor



The collector on the control panel's output must be connected to the alarm input's signal side.

This connection can keep the control panel galvanically isolated from the alarm transmitter if the transistor is, for example, the output from an optically-coupled isolator.

An order must be placed to change the service or the control of the alarm. Contact AddSecure for additional information about orders and changes to the alarm transmitter. Local programming is not necessary.

6.5 Relays (outputs)

| PIN | FUNCTION |
|-----|---------------------------|
| 1 | Relay 1 – Normally closed |
| 2 | Relay 2 – Normally closed |
| 3 | Relay 1 – Common |
| 4 | Relay 2 – Common |
| 5 | Relay 1 – Normally open |
| 6 | Relay 2 – Normally open |
| 7 | Relay 3 – Normally closed |
| 8 | Relay 4 – Normally closed |
| 9 | Relay 3 – Common |
| 10 | Relay 4 – Common |
| 11 | Relay 3 – Normally open |
| 12 | Relay 4 – Normally open |

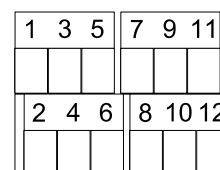

Figure 9 – Relay terminal block

6.5.1 Error indication

Relay 3 (FAULT) is used to signal errors when the alarm transmitter is used for fire alarms.

Connection: Connect relay 3 with pin 11 (normally open) and pin 9 (common) to the alarm panel at the appropriate input so that the alarm panel can detect a short circuit/open circuit on the connection.

- Status: Ok.
The relay is closed when the alarm transmitter is fully functional.
- Status: Error.
The relay opens in the event of an error or when the alarm transmitter is not fully functional; for example, if there is a restart or when the alarm cannot be sent or when no acknowledgment is received from the alarm receiver.

6.5.2 Indication of ongoing alarm

Relay 4 (ACK) is used when the alarm transmitter is configured for fire alarms and to indicate that the alarm transmitter has ongoing alarms.

Connection: Connect relay 4 with pin 12 (normally open) and pin 10 (common) to the alarm panel at the appropriate input so that the alarm panel can detect a short circuit/open circuit on the connection.

- Status: Normal.
The relay is opened when all fire alarms have been reset and acknowledged from the alarm receiver.
- Status: Alarm in progress
The relay closes then fire are in progress.

6.6 Ethernet connection (broadband)

Whenever Ethernet is included in the service, ETH0 is to be connected to Internet or the customer network for external communications for the service.

6.6.1 Firewall configuration

All communication, keep state, is initiated by the alarm transmitter to the service platform.

| FROM (Sender) | TO (Listener) | DESTINATION PORT | PRUPOSE |
|---------------|--|-----------------------------|-------------------------|
| Tor V | 85.117.160.240/28, 85.117.163.239, 85.117.163.240/28 | 7190, 7195 / TCP and UDP | AddSecure alarm service |



85.117.160.240/28 corresponds to: 85.117.163.240/28
corresponds to:
85.117.160.240 – 85.117.160.255 85.117.163.240 – 85.117.163.255

6.7 Wireless connection

The alarm transmitter is equipped with an FME male connector for an external antenna. The external antenna is to be equipped with an FME female connector.

6.8 Reading the signal strength

The signal strength can be read when the alarm transmitter's power supply is restored after an absence of voltage. The LED status indicates the current strength in four steps. The highest value indicates the current signal strength. For more details, see the appendix.

| INDICATOR | SIGNAL STRENGTH | SATISFACTORY | DIODE COLOR |
|-----------|-----------------|--------------|-------------|
| LED A | >25 | Yes | Green |
| LED B | 20–25 | Yes | Yellow |
| LED C | 14–19 | Yes | Red |
| LED D | 0–13 | No | Red |

To return to normal mode, press the opening tamper switch for five seconds or put on the cover so that the switch for the opening tamper is pushed down.



Note that the alarm transmitter does not work when you are reading the signal strength. The alarm transmitter cannot send any alarms, and the alarm center will be notified that the alarm transmitter is turned off.

6.9 Serial ports

Whenever serial ports are included in the service, S2 is connected to the serial equipment. The connector is of the type RJ12, and the electrical user interface is RS232.

| S2 | NAME | FUNCTION |
|----|-------|-----------------|
| 1 | Tx | Transmit |
| 2 | Rx | Receive |
| 3 | RTS | Request to send |
| 4 | CTS | Clear to send |
| 5 | Power | +5VDC |
| 6 | GND | Ground |



Note that serial interface is only for additional information. You must use the input interfaces to follow the regulations (EN 54-21:2006, EN 50136/SSF 114)

6.9.1 Example of a cable for connecting the control panel

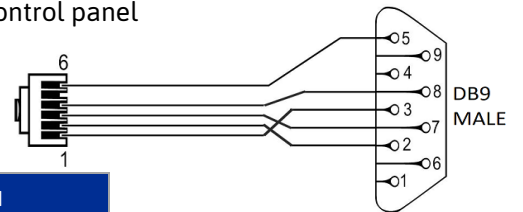

| PIN CPU | CABLE | PIN CONTACT | FUNCTION |
|---------|--------|-------------|-----------|
| 1 | Green | 3 | Tx → Tx |
| 2 | Yellow | 2 | Rx ← Rx |
| 3 | Orange | 7 | RTS → RTS |
| 4 | Brown | 8 | CTS ← CTS |
| 5 | Red | | +5VDC |
| 6 | Black | 5 | GND GND |

Figure 10 – Example of cable for control panel

A 5-meter ready-to-go is available as an option and can be ordered. Article number: 80 321 329

6.9.2 Example of a null modem cable for connecting a PC

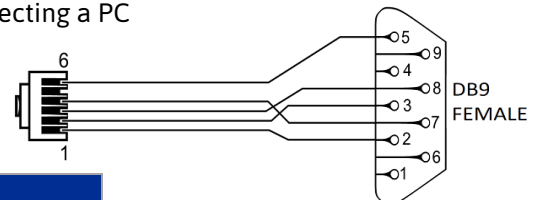

| PIN CPU | PIN CONTACT | FUNCTION |
|---------|-------------|-----------|
| 1 | 2 | Tx → Rx |
| 2 | 3 | Rx ← Tx |
| 3 | 8 | RTS → CTS |
| 4 | 7 | CTS ← RTS |
| 5 | | +5VDC |
| 6 | 5 | GND GND |

Figure 11 – Example of a null modem cable

6.10 Analogue dialler

The alarm transmitter acts as a switchboard and picks up automatically when the control panel dials using the modem's output. If the control panel sends information in SIA format or Contact ID (CiD), it is read and then forwarded to the connected alarm center. For this to happen, you need to have ordered the plain text SIA service or Contact ID. The control panel is to be programmed with an optional telephone number, consisting of six (6) digits.

Connecting the control panel with an analogue dialler is done with the tele terminal pair; see Figure 12. The number of the pin is not important.

Transferring alarms through the control panel's telephone connection (PSTN) is also called dial-capture. With this service, the alarm transmitter acts as an analogue telephone network, which it simulates by:

Figure 12 -
Tele terminal block

- Producing line voltage (approx. 30 volt).
- Generating a dial tone when the connected control panel picks up the receiver.
- Receiving DTMF signals from the control panel (number dialing).

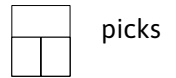

The next step in receiving a SIA or Contact ID message that the control panel transmits through its telephone connection is for the alarm transmitter to simulate an alarm receiver.

It does this by sending and receiving the signal that the SIA or Contact ID protocol uses. In this way, the alarm transmitter receives and acknowledges messages that the control panel sends through its telephone connection. After the transmission from the control panel is complete, the message is stored in the alarm transmitter and is forwarded through AddSecure's system to a preset alarm receiver. The alarm transmitter deletes the locally stored messages when the system acknowledges that the messages have been forwarded on.



Note that dialler interface is only for additional information. You must use the input interfaces to follow the regulations (EN 54-21:2006, EN 50136/SSF 114)



Must not be connected to the general telephone network (ordinary telephone jack/PSTN). The telephone line connection can only be connected to the control panels to use the analogue dialler.



The terminal block supplies 30V of line voltage with a ring signal according to the PSTN standard.

7 TESTING THE FIRE ALARM INSTALLATION (EN 54-21:2006)

To test the communication alarm between the control panel and the alarm transmitter as well as between the alarm transmitter and the alarm receiver, disconnect the current power supply for the alarm transmitter. Then check the control panel for errors (see 6.5.1) and with the alarm receiver for a disruption in communication. Then reconnect the power supply, and check that the control panel and the alarm receiver have been reset for each alarm.

8 MAINTENANCE

The alarm transmitter does not require any periodical maintenance.

An order must be placed to change the service or the control of the alarm. Contact AddSecure for further information about placing orders and making changes to the alarm transmitter. Local programming is not necessary.

9 TROUBLESHOOTING

9.1 All diodes are blinking at the same time

If the alarm transmitter gets its power from the control panel, check that there is no current limitation for the control panel. The alarm transmitter can use up to 3A at 24V DC during startup with a built-in battery backup or 2A at 12V DC without a battery backup.

9.2 The A diode is blinking and the C diode is turned off

The alarm transmitter does not have contact with the mobile network. Check the cables and the antenna. The cables must not be spliced or pinched. The antenna must not be placed in a steel cabinet, near fluorescent lamps, or close to other equipment that may interfere.

9.3 Weak signal strength

Check the cables and connect the external antenna. The cables must not be spliced or pinched. The antenna must not be placed in a steel cabinet, near fluorescent lamps, or close to other equipment that may interfere.

9.4 No Internet connection

Check that the network cable is in ETH0 and that the cable is a patch cable.



Some models of gigabit switches have had problems with the alarm transmitter. If needed, mount a 10/100 switch between the gigabit switch and the alarm transmitter to fix the problem.

10 DATA SHEET TOR V

| SECURITY | | | |
|---|--|---|---|
| Classification | Grade 2–4 DP4, SP5 D4 / M4 / T5 / A4 / S2 / I3 (Eth & Radio) | | |
| POWER SUPPLY | | | |
| Type | External power supply compliant with EN 50131-6 | | |
| Voltage | +12V DC to +30V DC | | |
| Current, normal usage (maximum) | 150mA (2 A) at 24V | | |
| WIRELESS ALARM TRANSFER | | | |
| Mobile data transfer | 2G, 3G, and 4G | | |
| Antenna connection | FME female | | |
| Maximum cable length | See the specification for the external antenna and cables | | |
| ETHERNET INTERFACE | | | |
| WAN connection | 1 unit (ETH0) | | |
| LAN connection | 1 unit (ETH1) | | |
| Connector | Modular RJ45 | | |
| Speed | 10/100 Base-T | | |
| Maximum cable length | 30 meters | | |
| Cable type | CAT5, shielded | | |
| SERIAL INTERFACE | | | |
| RS232 | 2 units (S1 & S2) | | |
| Connector | Modular RJ12 | | |
| ESPA support | ESPA-4.4.4 | | |
| Maximum cable length | 15 meters | | |
| ALARM INPUTS | | | |
| Inputs | 8 analogue or digital inputs with internal pull-up | | |
| Maximum cable length | 30 meters | | |
| Voltage across open input | +5V | | |
| Analogue | Balanced 4.7kΩ ±1kΩ | | |
| TELECOMMUNICATIONS CONNECTION FOR PLAIN TEXT | | | |
| Telephone input | 1 (pluggable terminal block) | | |
| SIA support | SIA DC-03-1990.01 | | |
| Contact ID support | SIA DC-05-1999.09 | | |
| Maximum cable length | 10 meters | | |
| RELAY | | | |
| Quantity | 4 relays with alternating output | | |
| Maximum voltage | 30 DC | | |
| Maximum current | 2 A | | |
| INDICATORS | | | |
| LEDs | 4 | | |
| ARC | | | |
| Protocol | <table border="0"> <tr> <td><u>Full functionality</u> MGXP 1131 SOS Access V4</td> <td><u>Without support for SIA & ESPA</u> MGXP 1129 SOS Access V3 Online Coordcom</td> </tr> </table> | <u>Full functionality</u> MGXP 1131 SOS Access V4 | <u>Without support for SIA & ESPA</u> MGXP 1129 SOS Access V3 Online Coordcom |
| <u>Full functionality</u> MGXP 1131 SOS Access V4 | <u>Without support for SIA & ESPA</u> MGXP 1129 SOS Access V3 Online Coordcom | | |
| ENVIRONMENT | | | |
| Temperature (surroundings) | -10 °C till +55 °C | | |
| Humidity | Maximum 95%, non-condensing | | |
| Environmental class | II | | |
| PHYSICAL PROPERTIES | | | |
| Dimensions | 249 mm × 220 mm × 55 mm (L × W × H) | | |
| Weight | 565 g | | |

APPENDIX – STATUS INDICATORS FOR TOR V



When powering up from an absence of voltage and before the tamper spring is pushed down, table 1 applies. After the spring is pushed down and the signal strength has been shown, table 2 applies. When warm booting the transmitter, the signal strength is not displayed and table 2 applies directly.

LED function during power-up

1. LED A blinks at start. Other LEDs are off.
2. When the alarm transmitter has contact with the mobile network, LED A's light is solid.
3. If the alarm transmitter does not have contact with the mobile network or if the signal strength cannot be measured, LED D blinks quickly.
4. The diodes indicate the signal strength of the mobile data network; see Table 1.
5. To return to normal mode, push down the opening tamper switch for five seconds or put on the cover so that the switch for the opening tamper is pushed down.
6. The LEDs display as normal no matter whether the interference protection is affected.

Table 1 (signal strength).

| Indicator | Status | Signal strength | Satisfactory | LED color |
|-----------|------------------|--------------------|--------------|-----------|
| LED A | On | >25 | Yes | Green |
| LED B | On | 20–25 | Yes | Yellow |
| LED C | On | 14–19 | Yes | Red |
| LED D | On | 0–13 | No | Red |
| LED D | Blinking quickly | Cannot be measured | No | Red |

Table 2 (normal display).

| LED A (Green) | |
|-----------------|---|
| Mode | Description |
| Off | Indicates that the alarm transmitter does not have power. |
| Double blinking | Indicates that the alarm transmitter does not have a mobile module or is in the process of starting up. |
| Blinking | The alarm transmitter has no contact with the mobile operator. |
| Solid | The alarm transmitter is connected to a mobile operator. |
| LED B (Yellow) | |
| Mode | Description |
| Off | Not used. |
| LED C (Red) | |
| Mode | Description |
| Off | The alarm transmitter has no contact with the alarm service via mobile data. |
| Blinking | The alarm transmitter has contact via the EDGE service. |
| Solid | The alarm transmitter has contact with the service via GPRS. |
| LED D (Red) | |
| Mode | Description |
| Off | The alarm transmitter has no outstanding alarms. |
| Solid | The alarm transmitter has outstanding alarms. |

APPENDIX – INSTRUCTIONS FOR MEASURING THE SIGNAL STRENGTH ON A COMPUTER

These instructions describe a general configuration for measuring the GSM signal strength on a computer. The measurement is only available before the alarm transmitter is commissioned; afterward, this function is turned off.

Requirements

To measure signal strength, you need:

- Computer with a browser
- Crossover Ethernet RJ45 TP network cable

Instructions

Here are only the details necessary to measure signal strength in your web browser.

1. Configure your computer for DHCP (you automatically get an IP address between 172.20.20.20 and 172.20.20.250).
2. Connect the computer to ETH 1 in the Tor V with a crossover network cable (Ethernet RJ45 TP).
3. Connect to this address using your browser: <http://172.20.20.1:3080>

You now see a number between 0 and 31. The number corresponds to the signal strength that the alarm transmitter currently has. The page is updated continuously.

If you need help configuring the computer, please turn to the IT department at your company and give them these instructions.

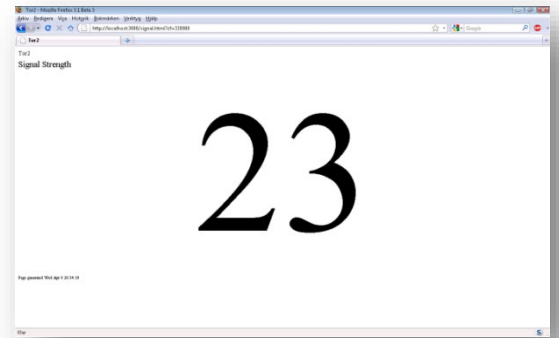



IMPORTANT! Information about test alarms related to disturbances

With the service you have, any triggered alarms **MUST** be acknowledged by your alarm center.

If there is a disturbance that causes the communication between the alarm transmitter and the alarm center to not work, the alarms will be stored in the alarm transmitter and sent as soon as the disturbance has been fixed. This is to always ensure that you know when the alarm has been triggered.

Example: You are notified by the alarm center or through, for example, AddView that there is a disturbance causing your service to not work. The alarm center will ask you to trigger a test alarm. The alarm will be stored and sent as soon as the service is running again.

AVOID triggering the fire alarm when there is a disturbance!

Instead trigger a “technical error.” Otherwise the alarm center will notify Rescue Services when the disturbance has been fixed and the alarm comes in. Rescue Services considers this to be a false alarm and will charge you for this.

Naturally this also applies to intruder alarms; the alarm center takes measures according to the above routine.

Speak with your electrician about how you easiest conduct a test alarm.



STOCKHOLM • OSLO • LONDON • GÖTEBORG • MALMÖ • ESPOO • ZUG
WWW.ADDSECURE.COM